

FV40 3/4" Float Operated Valve

For Diesel, Coolant, Light Oils, Kerosene and non-aggressive chemicals.

Applications include-

Overfill protection and level control of day tanks, storage tanks, process control and hydraulic fracturing unit refuelling.

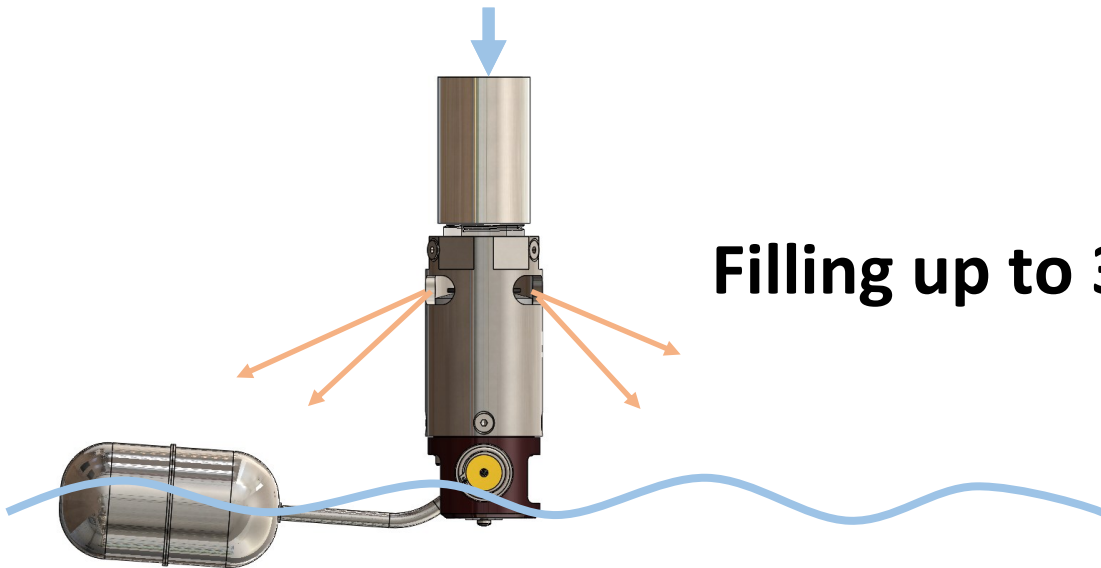

Filling up to 35L/min.

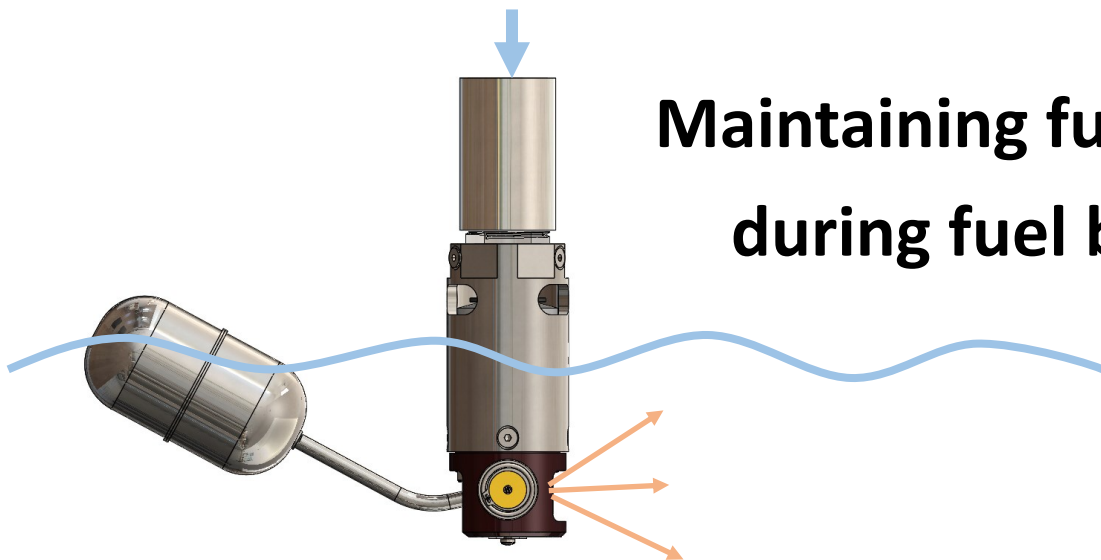

Maintaining fuel level during fuel burn.

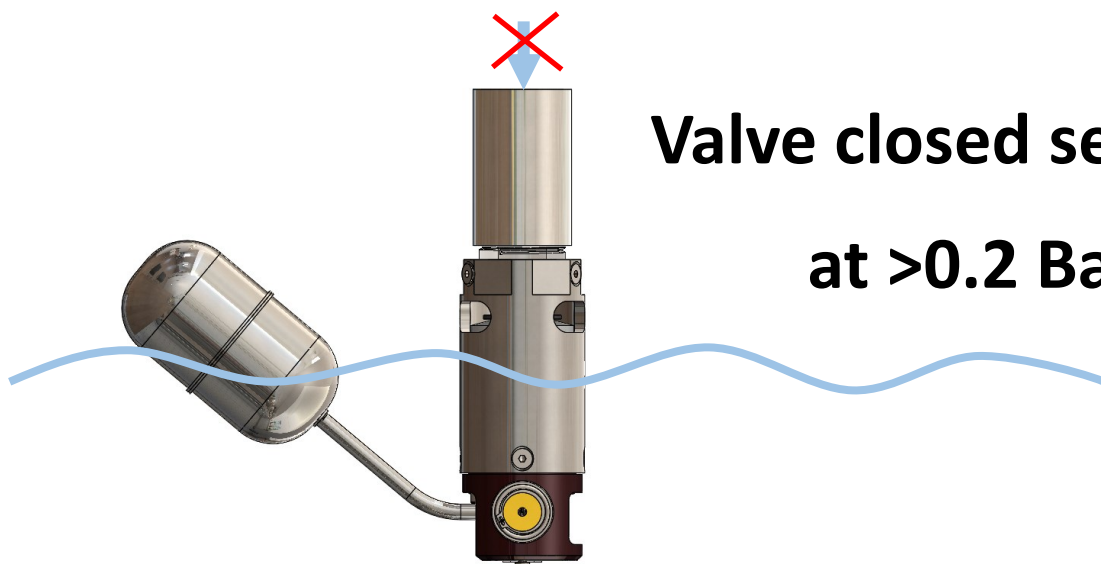

Valve closed seal tight at >0.2 Barg

Typical applications FV40 valve

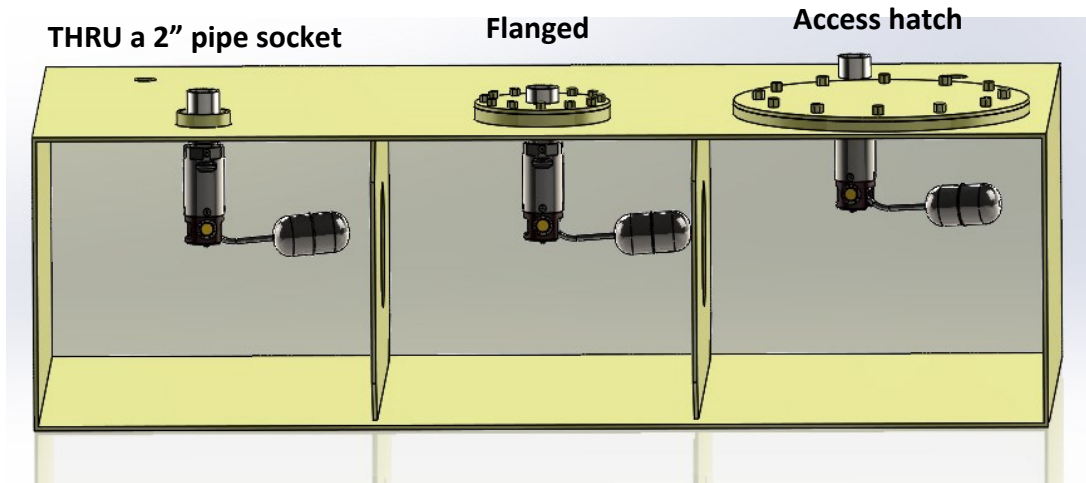

Diesel generators, Diesel driven fire pumps, Diesel driven irrigation pumps, storage tanks.

Suitable for Diesel, Coolant and light oils. Non-aggressive chemicals.

Cylindrical tank

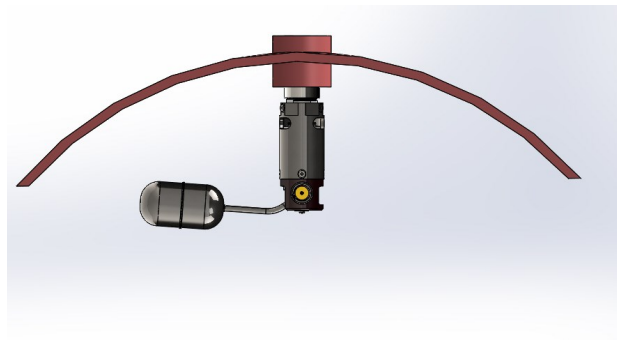

Installation.

Install and operate valve vertically.

Connection: 3/4" NPT.

Operating parameters.

Max operating pressure 5 Barg

Flow rate up to 35 L/min

Temperature—up to 60C

Materials:

SS 303. VITON. Brass

Float material: HD closed cell foam.

Mass:

568 grams

